



Service Manual for:
NVL
Vista
Series

Public Use Wheelchair Lifts

Series A5

DOT — Public Use Lift

"DOT — Public Use Lift" verifies that this platform lift meets the "public use lift" requirements of FMVSS No. 403. This lift may be installed on all vehicles appropriate for the size and weight of the lift, but must be installed on buses, school buses, and multi-purpose passenger vehicles other than motor homes with a gross vehicle weight rating (GVWR) that exceeds 4,536 kg (10,000 lb).



"Providing Access to the World"®

International Corporate Hdqrs: P.O. Box 310 Winamac, IN 46996 USA
1-800-THE LIFT® (574) 946-6153 FAX: (574) 946-4670



! WARNING

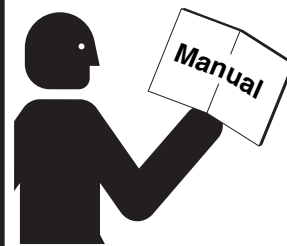

Read manual before installing or servicing lift. Failure to do so may result in serious bodily injury and/or property damage.

33917 Rev. A
February
2008

Patent #5,261,779 Patent #6,599,079
Patent #6,065,924 Patent #6,692,217
Patent #6,238,169 Patent #6,739,824
Patent #6,464,447 Patent #6,837,670 Patents Pending

Braun NVL Series

Congratulations

We at The Braun Corporation wish to express our fullest appreciation on your new purchase. With you in mind, our skilled craftsmen have designed and assembled the finest lift available.

This manual provides service-related material. Refer to the FMVSS No. 403 Quick Reference Installation Sheet for installation instructions, operating instructions and maintenance procedures.

Braun Vista Series™ lifts are built for dependability and will provide years of pleasure and independence as long as the lift is installed and serviced as specified by a Braun certified technician, and the lift is operated by an instructed person.

Sincerely,
THE BRAUN CORPORATION



Ralph W. Braun
Chief Executive Officer

Warranty and Registration Instructions

Immediately upon receiving the lift, examine the unit for any damage. Notify the carrier at once with any claims.

Two warranty/registration cards (shown right) are located in the lift-mounted manual storage pouch. The sales representative must process one of the cards. The consumer must fill out the other card and mail it to The Braun Corporation. The warranty is provided on the back cover of this manual. **The warranty cards must be processed to activate the warranty.**

Series No. Pump Code
Model No. Serial No. Cylinder Code

OWNER'S WARRANTY REGISTRATION

NVL917IB A5-00025 55 14CG

PURCHASED FROM _____

OWNER

NAME _____	DATE INSTALLED _____
ADDRESS _____	
CITY _____	
TELEPHONE _____	STATE _____ ZIP _____

TO VALIDATE WARRANTY
REGISTRATION CARDS MUST BE RETURNED TO THE BRAUN CORPORATION.

Sample Warranty/Registration Card

Two Braun Serial No./Series No. identification tags (shown below) are posted on the lift. One I.D. tag is posted on the opposite pump side vertical arm. A second I.D. tag is located on the opposite pump side tower. Both I.D. tags provide the product identification information provided on the warranty/registration card. Record the information in the space provided (or document on a copy). **This information must be provided when filing a warranty claim or ordering parts.**

The Braun Corporation
1-800-THE LIFT™
BRAUNLIFT.COM™

DOT Public Use Lift MODEL#

NVL917IB

Max. Lifting Capacity - 800 lbs.

SERIAL NUMBER

A5-00025

PUMP CODE	CYLINDER
55	14CG

MFG DATE

09/20/06

CE ^{cs}*72/245**95/54*0110*00
PATENT
PENDING- 5,261,779-6,065,924-6,238,169-6,46
4,447-6,599,079-6,692,217-6,739,824

Sample Serial No./Series No. Identification Tag

Model No. _____

Series No. _____

Serial No. _____

Pump Code _____

Cylinder Code _____

Date of Manufacture _____

Contents

Troubleshooting and Maintenance

Lift Terminology.....	2
Switch and Sensor Locations	3
Certification Checklist Diagnostic Procedures	4
Platform Fold Pressure Adjustment	5
Platform Angle Adjustment	6-7
Platform Stop Blocks	7
Platform Floor Level Adjustment	8
Bridging Microswitch Adjustment	9
LCD Lift Codes	10-11
Lubrication Diagram.....	12
Maintenance and Lubrication Schedule.....	13-16
Lift Electrical Schematic	17
Lift Wiring Diagram	18

Hydraulics

Hydraulic Schematic	19
Hydraulics Parts List	20
Hydraulics Diagram	21

Repair Parts

Pump Module	
Pump Module Parts List	22
Pump Module Diagram	23
Lift Exploded View	
Repair Parts List	24
Exploded View	25
Notes	26

Lift Terminology

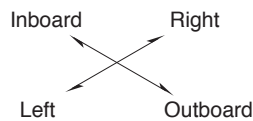
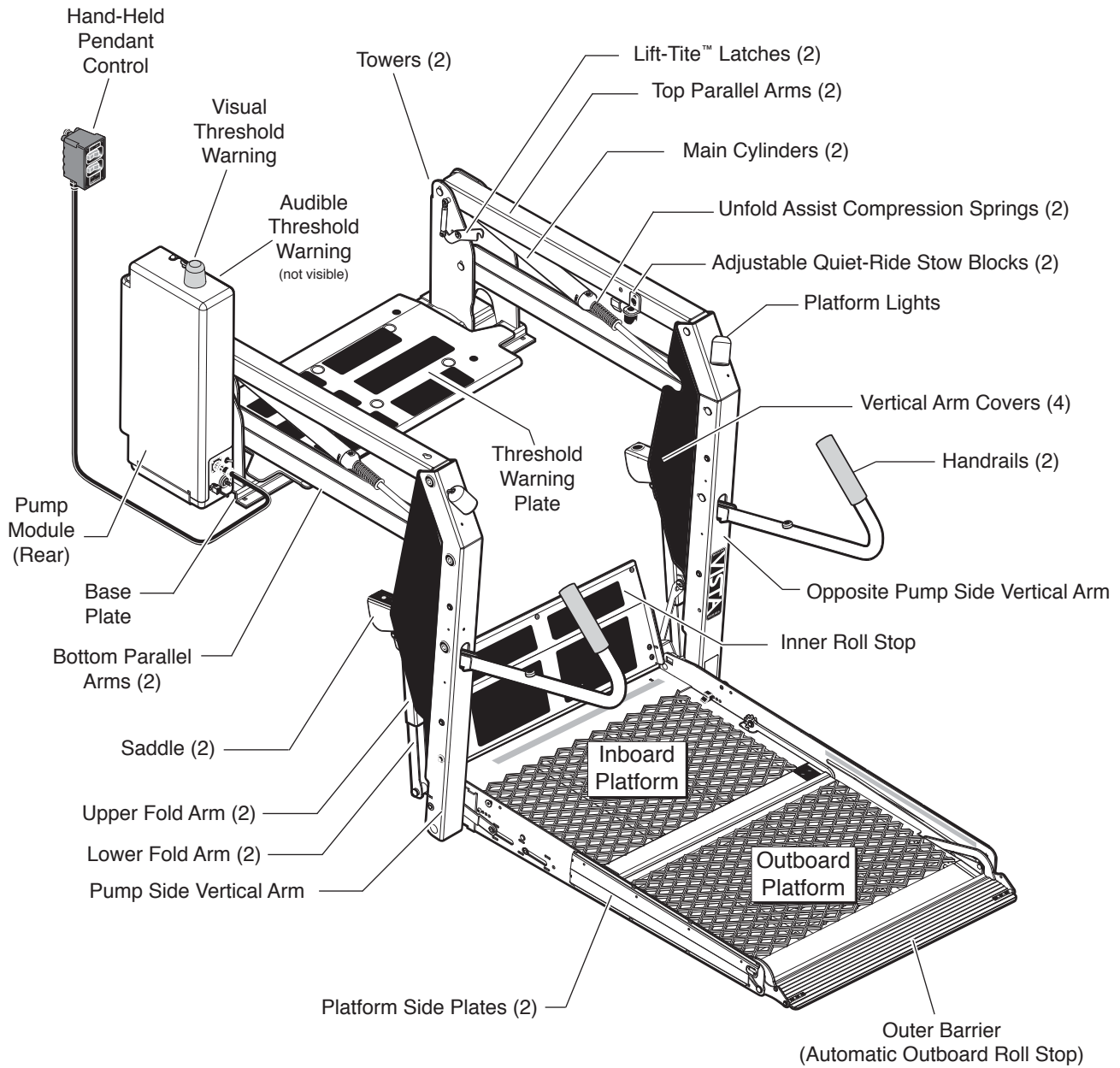

Switch and Sensor Locations

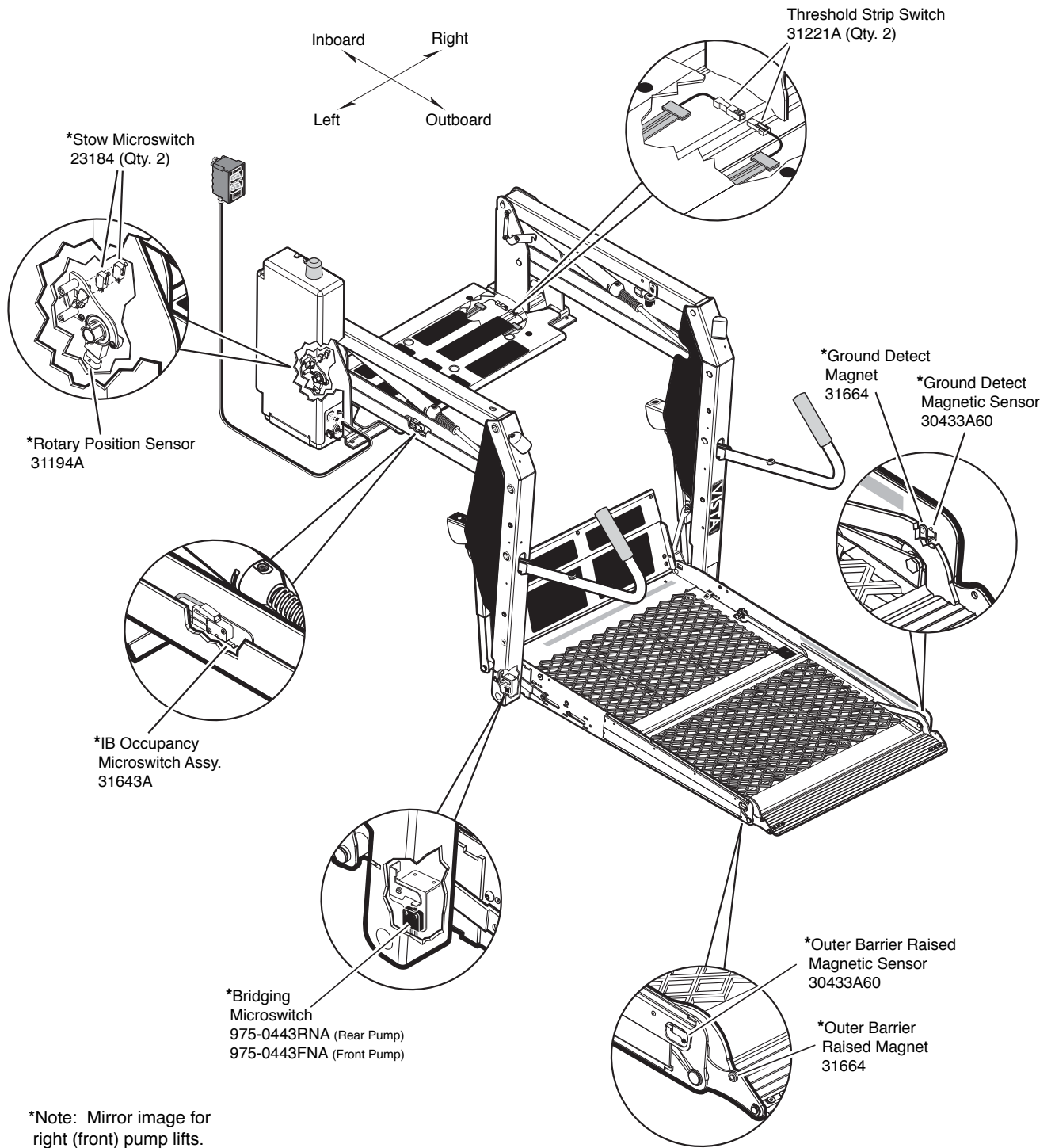

Certification Checklist Diagnostic Procedures

The following operations and conditions must be functionally verified in order for the lift to be FMVSS 403/404 compliant. If an operation does not function as described or a condition is not met, follow the referenced procedures to correct the problem or contact a Braun Corporation Product Support representative at 1-800-THE LIFT®.

- Vehicle movement is prevented unless the lift door is closed, ensuring the lift is stowed.
 1. Verify on the pump module mounted interlock connector that the lift not stowed signal (pin 5) has an open signal - OR - lift stowed signal (pin 7) has a +12 volt signal - OR - (pin 9) has a ground signal (depends on interlock used).
 2. Refer to the interlock installation instructions.

- Lift operation shall be prevented unless the vehicle is stopped and vehicle movement is prevented.
 1. Verify vehicle secure signal (pin 6) has a +12 volt signal.
 2. Refer to the interlock installation instructions.

- The platform will not fold/stow if occupied.
 - Refer to Platform Fold Pressure Adjustment procedures.

- The inner roll stop will not raise if occupied.
 - Call Product Support

- The outer barrier will not raise if occupied.
 - Call Product Support

- Verify platform lighting when lift is deployed and pendant illumination when lift is powered.
 1. Replace bulb(s) in the light housing.
 2. Check fuse (5 amp fuse on circuit board; F13)

- A visual and audible warning will activate if the threshold area is occupied when the platform is at least 1" below floor level.
 1. Remove the threshold warning plate
 2. Verify the threshold strip switch connectors are connected
 3. Replace the threshold strip switch
 4. Reinstall the threshold warning plate

- Platform movement is prohibited beyond the position where the inner roll stop is fully deployed (up).
 - Call Product Support.

- Lift platform movement shall be interrupted unless the outer barrier is deployed (up).
 - Call Product Support.

Platform Fold Pressure Adjustment

1. Position the platform at the floor level loading position.
2. Loosen the hex nut on the adjustment screw (do not remove hex nut).
3. Turn the adjustment screw counter clockwise until the platform does not fold when the Fold button is pressed.
4. Turn the adjustment screw clockwise in 1/4 turn increments and press the Fold button until the platform folds completely (Note: Return the platform to floor level position after each attempt to fold the platform).
5. Turn the adjustment screw an additional 1/8 turn after the platform folds successfully.
6. Tighten the hex nut without moving the adjustment screw.
7. Verify the platform will not stow while occupied.

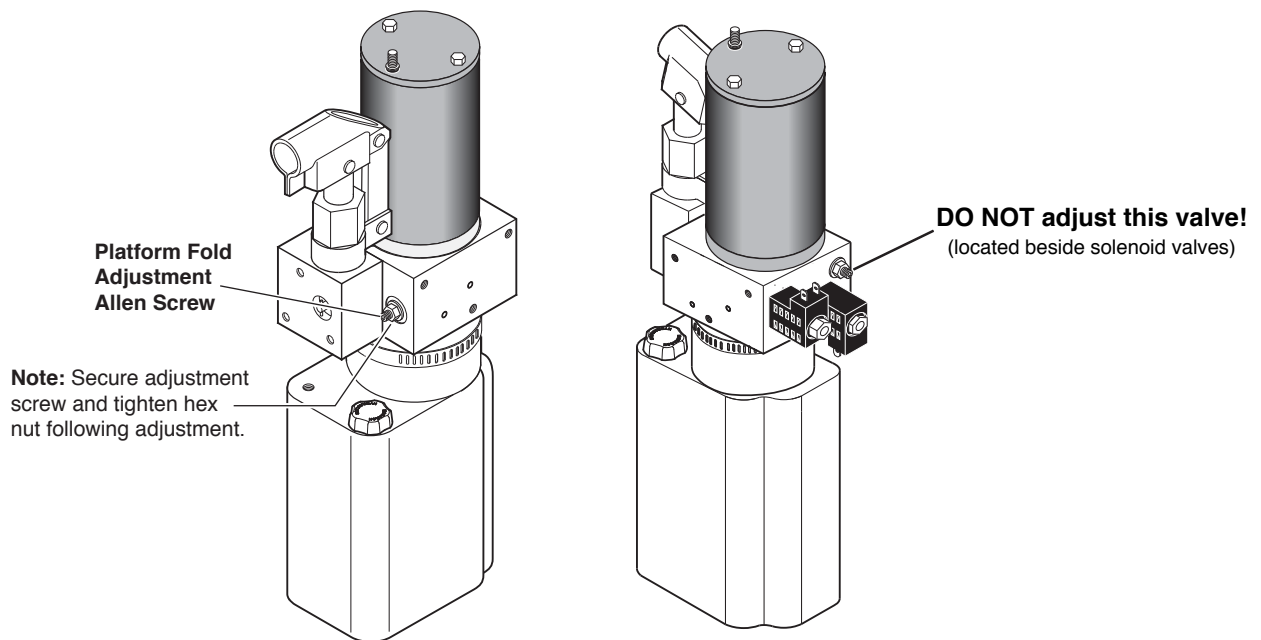

Platform Angle Adjustment

Adjusting the platform angle based on the relationship of the platform at ground level directly affects the angle of the platform when positioned at floor level.

Unfold the lift and visually examine the angle of the platform when positioned at floor level. Lower the platform fully and note the angle of the platform when it reaches ground level also. The **outboard end of the platform (toe) must contact the ground first** when the platform is lowered (all lift models).

Millennium “NL” Series:

The platform angle **should** be adjusted so there is a balance between the angle at both positions (**equal amount of angle**). **Angle A** should **equal angle B** as shown in Figure C.

Century “NCL” Series: Vista “NVL” Series:

The platform angle **must** be adjusted so the outboard end of the platform (toe) is angled down slightly when positioned at floor level. See Figure D. The outboard end of the platform **must** contact the ground first to **ensure** the spring-loaded outer **barrier unfolds fully**.

Adjustment Procedures: Adjustment Allen screws are provided on each side of the lift platform for adjusting the platform angle. Details and photos are provided on the opposite page.

Base Plate Wedges: Installations where base plate wedges are used require more platform angle adjustment than normal.

Platform Stop Blocks: When adjusting platform angle, ensure both **stop blocks are making full contact with the vertical arms** (details on opposite page).

Floor Level Adjustment: Following platform angle adjustment, set floor level positioning as detailed in **Platform Floor Level Adjustment** (details on page 8).

Millennium “NL” Series

Figure C

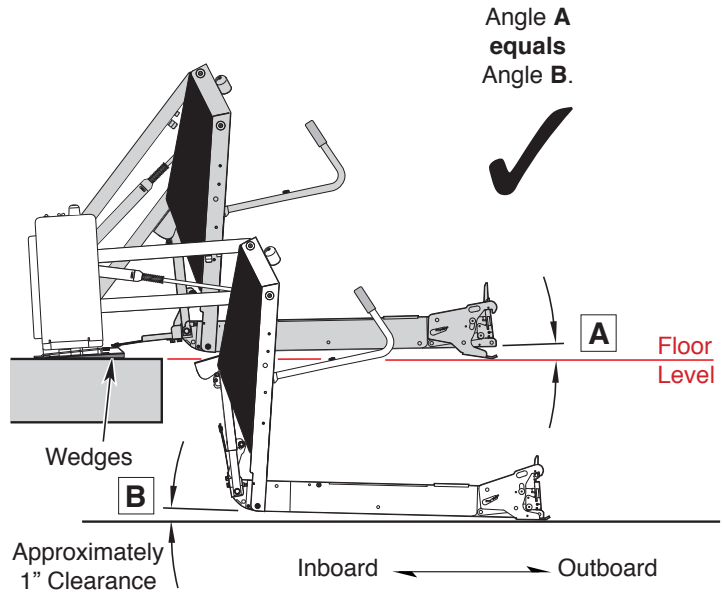

Century “NCL” Series

Vista “NVL” Series

Figure D

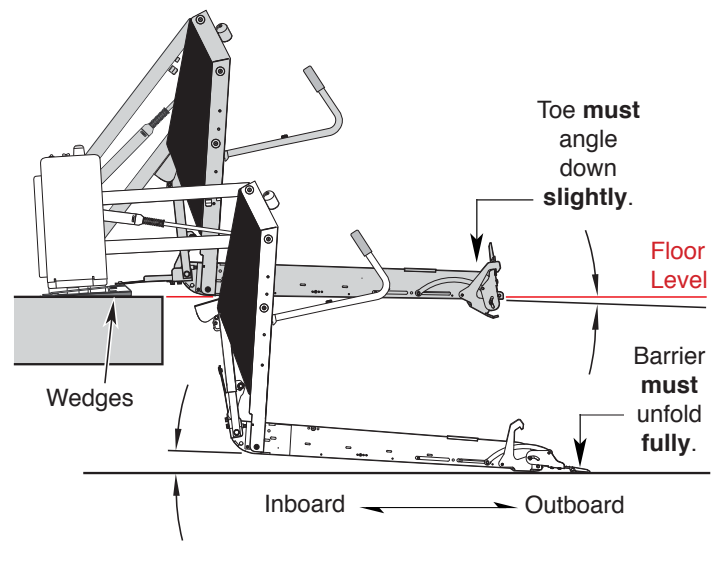

Platform Angle Adjustment

Adjustment Allen screws are provided on each side of the lift platform for adjusting the platform angle. Adjust platform angle as specified on previous page.

To **raise** the **outboard end** of platform - turn adjustment screw **clockwise**.

To **lower** the **outboard end** of platform - turn adjustment screw **counterclockwise**.

Note: Both adjustment screws **must be adjusted equally**.

Apply Loctite® to adjustment screws following adjustment.

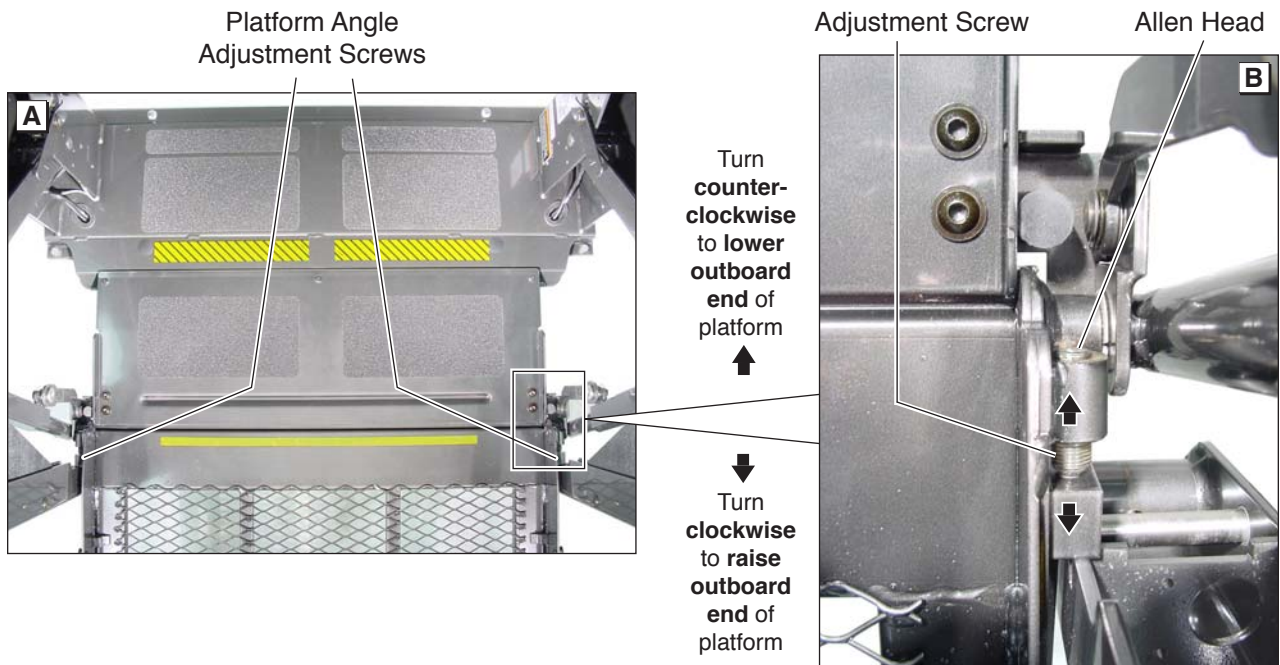

Platform Stop Blocks

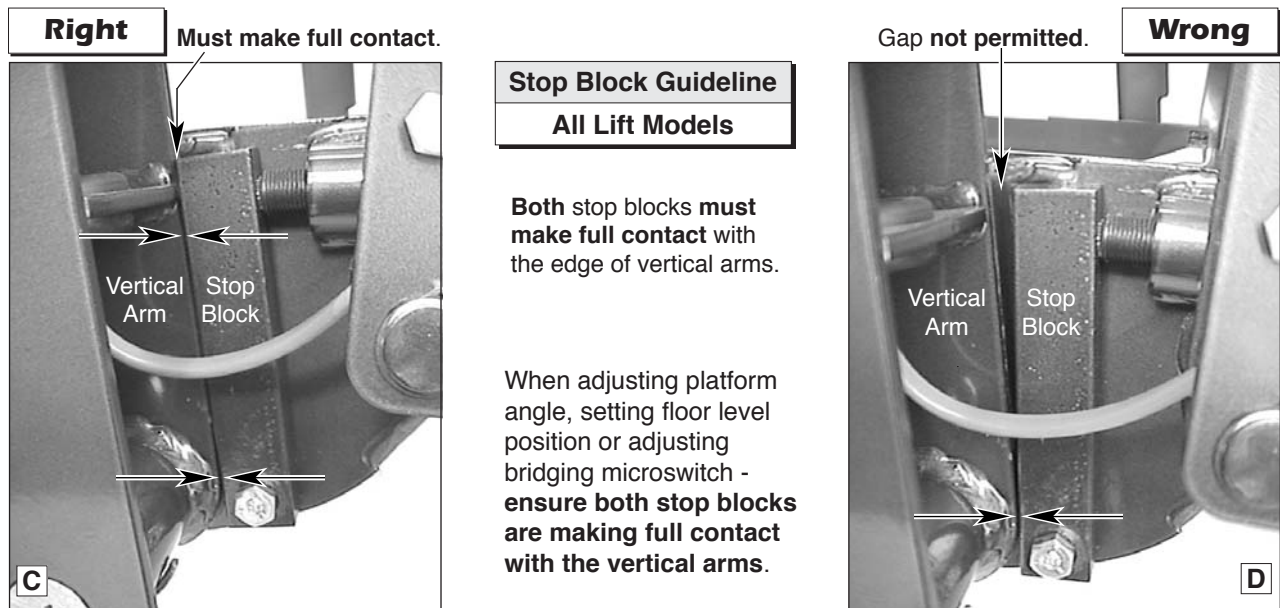

Platform Floor Level Adjustment

Before setting floor level position:

- Adjust platform angle as detailed on page 6.
- Ensure both **stop blocks are making full contact with vertical arms** (details on page 7).

Floor Level Adjustment:

1. Position platform at desired floor level position (passenger loading/unloading height).

Position platform such that:

- a. the inner roll stop is laying flat on the threshold plate
- b. platform has **not** begun to fold

Note: Use hand pump to position platform at proper posi-

tion if unable to stop platform when powering lift.

2. Turn Lift Power switch Off.
3. Press Floor Position Set button (located between pump housing and lift tower).
4. While pressing the Floor Position Set button, turn the Lift Power switch On.
5. Continue pressing the Floor Position Set button until the lift sounds three “beeps.”
6. Release the Floor Position Set button.
7. Cycle lift to verify that platform stops at the set floor level position. **Note:** If platform does not stop at



Floor Level Set Button

the intended position - repeat adjustment procedures. If repeating procedures fails - refer to Diagnostics section below.

Diagnostics: Diagnostic codes have been established in event the lift platform floor position does not set (the lift does not sound three “beeps” - see Step 5 above). The control board located inside the pump hous-

ing is equipped with an LCD screen. Remove the pump cover to access the LCD screen. The following diagnostic codes will help resolve floor position setting problems:

Century/Vista Jumper



- 91 – The platform position is out of a predetermined acceptable range
- 92 – The Bridging Microswitch is not activated (adjust switch or lower the platform)
- 93 – The Inner Roll Stop Occupied switch is not activated (adjust switch)
- 94 – The Outer Barrier Up switch is not activated (adjust switch)
- 95 – The Outer Barrier Latched sensor is not activated (Century and Vista: Verify jumper is installed on the outboard barrier latch switch – see photo at right; Millennium: Check latch)

LCD Screen



Bridging Microswitch Adjustment

Bridging Microswitch:

The bridging microswitch is located at the bottom of the right (front) vertical arm. See Photos A and B. An adjustment screw is built into the platform stop block.

The bridging microswitch will be deactivated if the outboard end of the platform contacts the unloading surface before the inboard end while the DOWN switch is pressed.

The deactivated bridging microswitch interrupts power to the DOWN switch circuit and stops the down travel of the platform (while allowing the outer barrier to deploy).

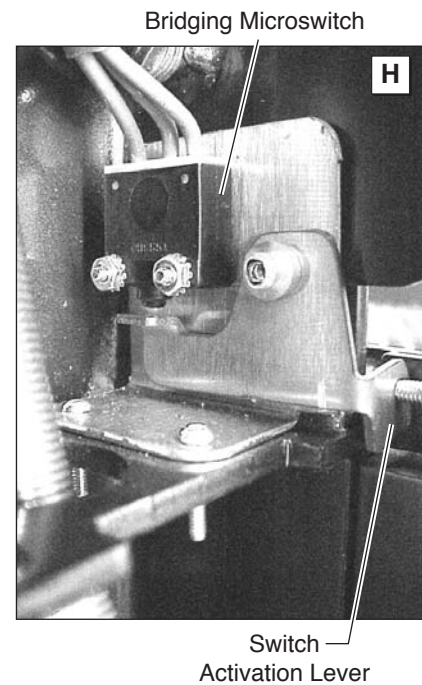
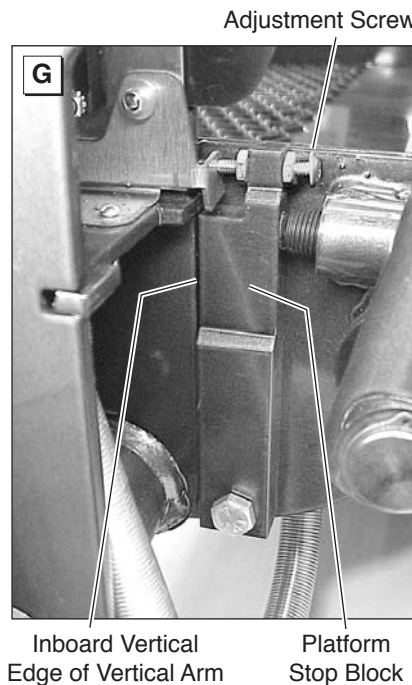

Adjustment Guidelines:

Caution: This adjustment is factory set and typically should not require adjustment.

Before adjusting the bridging microswitch:

- Adjust platform angle as detailed on page 6.

- Adjust floor level position as detailed on page 8.
- **Ensure** platform is in the fully unfolded position.
- **Ensure** both stop blocks are making full contact with vertical arms (details on page 7).

Failure to follow these guidelines will result in an overtight adjustment that will bend the adjustment screw, break the bridging switch and/or result in lift operation failure.

Bridging Microswitch Adjustment

1. Position the platform at floor level (or slightly below). Ensure the platform is not partially folded. From the stowed position, press the UNFOLD switch until the pump stops running and the platform comes to a full stop. From below floor level, press the UP switch until the pump stops running and the platform comes to a full stop.
2. Check **both** platform stop blocks to **ensure there is no gap** between the stop blocks and the vertical arms. See Photos B, C and D on page 7. A gap may indicate that the platform is not fully unfolded or the platform angle adjustment bolts are not adjusted equally on both sides.
3. Loosen the two jam nuts on the bridging switch activation screw (see Photo G). Tighten the screw until the activation lever is fully depressed. Verify that there is no play in the activation lever and tighten the jam nuts.
4. Test lift for proper operation.

LCD Lift Codes

To better understand the Braun LCD Trouble shooting display you must first understand the numbers that appear on the screen. There are Flashing Codes, Solid Error Codes, and Solid Normal Operational Codes.

Flashing Codes #65-89: About 10 seconds after an operation has stopped there are a set of scrolling flashing numbers that indicate whenever a particular sensor or switch has been activated. These numbers will start at number 65 and scroll up to number 89, then start the sequence over. Remember they are not error codes. Keep in mind that the lift will display codes for different positions and certain flashing codes must be present for that position, you will not always get an error code.

Solid Error Codes #50-64: These are the numbers that will come on the screen when the audible and visual alarm goes off, and will direct you to where the problem exists. These numbers will only stay on the screen for about 10 seconds and then the flashing codes will scroll indicating what sensors are active. This sequence of codes will keep repeating. It is important to be looking at the screen when trying to get the lift to fail.

Solid Normal Operational Codes: There are also solid numbers that will appear while and after the lift is moving that indicate the lift operation and platform position.

Troubleshooting Procedures

1. While **looking** at the LCD screen, operate the lift until the failure occurs. Read the number that comes on the display the moment the alarm goes off and the light starts to flash. This code will only stay on the screen for 10 seconds.
2. Look up the number on the correct error code sheet and determine what part on the lift is causing the failure. Go to the part on the lift that is suspected of causing the failure and look for anything obvious like magnets missing, broken wires etc. If nothing is found, the next step is to determine if that sensor is sending a signal to the board.
3. Bring the platform to the level that the sensor should be activated using the backup pump if needed. At this point, look up the flashing code that corresponds to that sensor in the error code sheet, look at the LCD screen and wait for the flashing scrolling numbers to appear. If the number is not included in the scrolling numbers, you know that sensor is the problem. You should then check the harness or try another magnet with the south side of the magnet facing the sensor and see if the number will come up on the display.
4. If the problem is still not found or the harness is suspected, the voltages should to be checked to and from the sensor to find the exact location of the problem. First determine the 3 wire colors for this sensor at the board and understand the 3 voltage readings needed to operate the sensor, the 12V power, 8V power, and the 8V input signal to the PC board when activated by a magnet. First check for a 8V input signal coming from the sensor to the wire going into the PC board, if there is 11V on this wire, the sensor is not being activated by the magnet. Next check the 12V and 8V wires at the PC board plug leading to the sensor. Once verified at the plug on the PC board, the voltages should then be checked at the next plug down on the harness going to the sensor until the location of the problem is found.

Anytime you see the code for that specific switch you will have 8 volts on that colored wire on the 8 or 18 pin connector from that switch. IE: Outboard Barrier is closed "72" will appear on the screen and also 8V will be present on the signal wire from that switch, if no code is present the voltage will be 11V.

LCD Lift Codes

Listed below are codes that the lift controller outputs during lift operation. The codes will be displayed on an LCD screen located on the lift control board inside the pump module. See the Manual Operating Instructions in the operator's manual for pump cover removal instructions.

Non-Flashing Numbers

- 01 – Platform stowed
- 02 – Platform unfolding
- 03 – Platform unfolding paused
- 04 – Platform at floor level
- 05 – Platform beginning to lower
- 06 – Platform lowering (threshold cannot be occupied from this point down)
- 07 – Outer barrier moving to horizontal position
- 08 – Platform at ground level
- 09 – Outer barrier moving to vertical position
- 10 – Platform raising
- 11 – Platform raising paused at floor
- 12 – Platform folding (limited pressure)
- 13 – Platform folding (full pressure)
- 14 – Timed fold (cinching lift tite) or (anti-rattle state)
- 15 – Platform folding stopped
- 16 – Paused fold
- 17 – Platform between ground and 3” above ground
- 18 – Platform above 3”
- 19 – Outer barrier moving to horizontal position
- 23 – Outer barrier going back down after occupant detected
- 28 – Illegal function/not defined
- 29 – Interlock fault not recognized (or has been cleared but a motion button is still pressed)
- 30 – Platform location unknown
- 31 – Platform location transition state; attempting to locate position
- 35 – Two or more motion buttons are being pressed
- 36 – The retention belt cannot be buckled while trying to fold or unfold
- 37 – Motion button being pressed is not a valid motion
- 50 – Outer barrier is not up above inboard barrier locked position
- 51 – Threshold is occupied when platform is 1” or more below floor level
- 52 – Inner rollstop is not up and locked below inner rollstop locked position
- 53 – Inner rollstop occupied sensor is not activated between floor and inner rollstop up position
- 54 – Outer barrier is occupied before it is up
- 55 – Outer barrier is not latched when above the inner rollstop locked position (Millennium only)
- 56 – Outer barrier is not up and latched and bridge switch did not deactivate
- 57 – Outer barrier is not up and latched and ground detect switch did not deactivate (Century and Vista only)
- 58 – Outer barrier is not up and latched and the platform is 3” above the ground
- 59 – Outer barrier is not up after pausing platform travel
- 60 – Verify the IB occupied switch is functioning correctly when lift is below floor level. The kickout gas springs are worn, replace before using
- 75 – Low voltage detected; must turn off power switch to reset LCD
- 77 – Vehicle secure interlock has not been activated
- 90 – Position will be set if you keep holding the button until it beeps
- 91 – Position is out of a predetermined acceptable range of floor position
- 92 – Bridge switch is not made, needs adjusting
- 93 – Inner rollstop occupied switch is not made, position needs to be moved or switch should be adjusted
- 94 – Outer barrier is not made, fix and try again
- 95 – Outer barrier latch is not made (check for jumper on Century and Vista lifts, check latch on Millennium lifts)
- 99 – Controller program is not valid; replace controller

Flashing Numbers

- Flashing 65 – Unfold button is pressed
- Flashing 66 – Fold button is pressed
- Flashing 67 – Down button is pressed
- Flashing 68 – Up button is pressed
- Flashing 69 – Bridge switch is activated
- Flashing 70 – Outer barrier latch switch is activated
- Flashing 71 – Ground detect switch is activated
- Flashing 72 – Outer barrier up switch is activated
- Flashing 73 – Inner rollstop up switch is activated
- Flashing 74 – Inner rollstop occupied switch is activated
- Flashing 76 – Outboard barrier occupied switch is activated
- Flashing 78 – Threshold tape switch “A” is activated
- Flashing 79 – Threshold tape switch “B” is activated
- Flashing 80 – Position set button is pressed

Maintenance and Lubrication

Lubrication Diagram

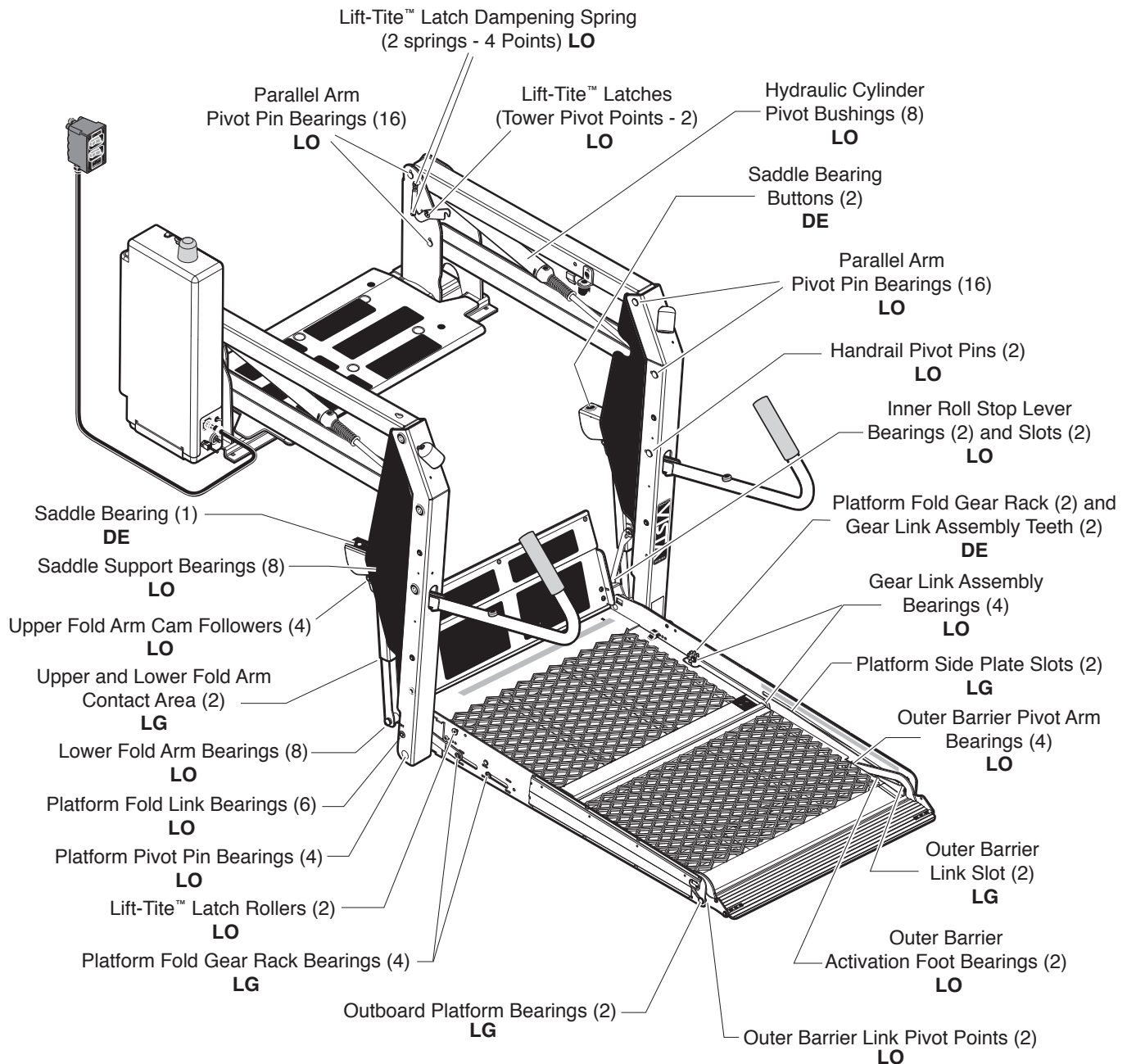

See the Maintenance/Lubrication Schedule for recommended applications per number of cycles.

Lubricant	Type	Specified (recommended) Lubricant	Available Amount	Braun Part No.
LO - Light Oil	Light Penetrating Oil (30 weight or equivalent)	LPS2, General Purpose Penetrating Oil	11 oz. Aerosol Can	15807
DE - Door-Ease	Stainless Stick Style (tube)	Door-Ease Stick (tube)	1.68 oz.	15806
LG - Light Grease	Light Grease (Multipurpose)	Lubriplate	14 oz. Can	15805

Maintenance and Lubrication Schedule

Proper maintenance is necessary to ensure safe, troublefree operation. Inspecting the lift for any wear, damage or other abnormal conditions should be a part of all transit agencies's daily service program. Simple inspections can detect potential problems.

The maintenance and lubrication procedures specified in this schedule **must** be performed by a Braun authorized service representative at the scheduled intervals according to the number of cycles.

Braun dual parallel arm lifts are equipped with hardened pins and self-lubricating bushings to decrease wear, provide smooth operation and extend the service life of the lift.

When servicing the lift at the recommended intervals, inspection and lubrication procedures specified in the previous sections should be repeated. **Clean** the components and the surrounding area **before applying lubricants**. LPS2 General Purpose Penetrating Oil is recommended where Light Oil is called out. Use of improper lubricants can attract dirt or other contaminants which could result in wear or damage to the components. Platform components exposed to contaminants when lowered to the ground may require extra attention.

Lift components requiring grease are lubricated during assembly procedures. When these components are replaced, grease must be applied during installation procedures. Specified lubricants are available from The Braun Corporation (part numbers provided above).

All listed inspection, lubrication and maintenance procedures should be repeated at "750 cycle" intervals

following the scheduled "4500 Cycles" maintenance. These intervals are a general guideline for scheduling maintenance procedures and will vary according to lift use and conditions. Lifts exposed to severe conditions (weather, environment, contamination, heavy usage, etc.) may require inspection and maintenance procedures to be performed more often than specified.

⚠ WARNING

Maintenance and lubrication procedures must be performed as specified by an authorized service technician. Failure to do so may result in serious bodily injury and/or property damage.

Maintenance Indicator: The Lift Ready green LED mounted on top of the pump cover will begin to blink after every 750 cycles. The blinking LED will not affect the functions of the lift, but is a reminder to complete necessary maintenance and lubrication.

Once the lift has been serviced, fully stow the lift. Once stowed, press the UP button on the hand pendant and the Floor Level Set button on the back side of the pump cover until the Lift Ready green LED stops blinking.

Discontinue lift use immediately if maintenance and lubrication procedures are not properly performed, or if there is any sign of wear, damage or improper operation. Contact your sales representative or call The Braun Corporation at 1-800-THE LIFT®. One of our national Product Support representatives will direct you to an authorized service technician who will inspect your lift.

750 Cycles	Outer barrier link pivot points (2)	Apply Light Oil - See Lubrication Diagram
	Outer barrier link slots (2)	Apply Light Grease - See Lubrication Diagram
	Gear link assembly bearings (4)	Apply Light Oil - See Lubrication Diagram
	Gear link assembly teeth (2)	Apply Door Ease - See Lubrication Diagram
	Outboard platform bearings (2)	Apply Light Grease - See Lubrication Diagram
	Platform fold link bearings (6)	Apply Light Oil - See Lubrication Diagram
	Platform fold gear rack bearings (4)	Apply Light Grease - See Lubrication Diagram
	Platform fold gear rack teeth (2)	Apply Door Ease - See Lubrication Diagram
	Lift-Tite™ latches (tower pivot points - 2)	Apply Light Oil - See Lubrication Diagram
	Lift-Tite™ latch gas (dampening) spring pivot points (2 springs - 4 points)	Apply Light Oil - See Lubrication Diagram

continued

Maintenance and Lubrication Schedule

750 Cycles	Inspect Lift-Tite™ latches and gas springs for wear or damage (bent, deformed or misaligned), positive securement (external snap rings) and proper operation	Resecure, replace damaged parts or otherwise correct as needed. Note: Apply Light Grease to Lift-Tite™ latch tower pivot point if replacing latch.
	Inspect outer barrier for proper operation	Correct or replace damaged parts.
	Inspect platform fold gear rack and gear weldment teeth for foreign objects, wear or damage (bent, deformed or misaligned), positive securement and proper operation	Remove foreign objects, replace damaged parts and resecure as needed
	Inspect lift for wear, damage or any abnormal condition	Correct as needed.
	Inspect lift for rattles	Correct as needed.

1500 Cycles	Perform all procedures listed in previous sections also	
	Outer barrier activation foot pivot bearings (2)	Apply Light Oil - See Lubrication Diagram
	Outer barrier pivot arm bearings (4)	Apply Light Oil - See Lubrication Diagram
	Upper fold arm cam followers (4)	Apply Light Oil - See Lubrication Diagram
	Upper/lower fold arms (2)	Apply Grease (synthetic) to contact areas between upper/lower fold arms. See Lubrication Diagram
	Platform pivot pin bearings (4)	Apply Light Oil - See Lubrication Diagram
	Lower fold arm bearings (8)	Apply Light Oil - See Lubrication Diagram
	Inner roll stop lever bearings (2)	Apply Light Oil - See Lubrication Diagram
	Inner roll stop lever slot (2)	Apply Light Oil - See Lubrication Diagram
	Saddle support bearings (8)	Apply Light Oil - See Lubrication Diagram
	Parallel arm pivot pin bearings (16)	Apply Light Oil - See Lubrication Diagram
	Handrail pivot pins (2)	Apply Light Oil - See Lubrication Diagram
	Hydraulic cylinder pivot bushings (8)	Apply Light Oil - See Lubrication Diagram
	Inspect Lift-Tite™ latch rollers for wear or damage, positive securement and proper operation (2)	Correct, replace damaged parts and/or relubricate.
	Inspect outboard roll stop feet for proper operation, positive securement and detached or missing torsion spring	Correct, replace damaged parts and/or relubricate.
Inspect inner roll stop for: <ul style="list-style-type: none"> • Wear or damage • Proper operation. Roll stop should just rest on top surface of the threshold (base) plate. • Positive securement (both ends) 	Resecure, replace or correct as needed. See Platform Angle Instructions and Floor Level Adjustment Instructions.	
Inspect handrail components for wear or damage, and for proper operation	Replace damaged parts.	

continued

Maintenance and Lubrication Schedule

<div style="border: 1px solid black; padding: 2px; display: inline-block;">continued</div>	<p>Inspect microswitches for securement.</p> <p>Make sure lift operates smoothly</p> <p>Inspect external snap rings:</p> <ul style="list-style-type: none"> • Lower fold arms (6) • Inner roll stop lever bracket pins (2) • Lift-Tite™ latch gas (dampening) springs (4) • Gear link assembly (4) • Lift-Tite™ Latch (2) • Vertical channel/platform link (2) • Upper fold arm cam followers (4) • Outer barrier pins (2) <p>Inspect inner roll stop locks and torsion springs for wear or damage and for proper operation.</p> <p>Inspect platform fold axles for wear or damage and positive securement</p> <p>Inspect platform fold link rollers and bearings for wear or damage and positive securement</p> <p>Remove pump module cover and inspect:</p> <ul style="list-style-type: none"> • Hydraulic hoses, fittings and connections for wear or leaks • Harness cables, wires, terminals and connections for securement or damage • Control board, circuit breaker, power switch and lights for securement or damage 	<p>Resecure or replace if needed.</p> <p>Realign towers and vertical arms. Lubricate or correct as needed.</p> <p>Resecure or replace if needed.</p> <p>Replace damaged parts. Apply Light Oil to inner roll stop lock pivot points.</p> <p>Replace damaged parts and resecure as needed.</p> <p>Resecure, replace or correct as needed. Note: Apply Loctite® to threads if needed.</p> <p>Resecure, replace or correct as needed.</p>
<p>1500 Cycles</p>		

<div style="border: 1px solid black; padding: 2px; display: inline-block;">Perform all procedures listed in previous section also</div>	<p>Inspect cotter pins on platform pivot pins (2)</p> <p>Hydraulic Fluid (Pump) - Check level. Note: Fluid should be changed if there is visible contamination. Inspect the hydraulic system (cylinder, hoses, fittings, seals, etc.) for leaks if fluid level is low.</p> <p>Inspect cylinders, fittings and hydraulic connections for wear, damage or leaks</p> <p>Inspect parallel arms, bushings and pivot pins for visible wear or damage</p> <p>Inspect parallel arm pivot pin mounting bolts (8)</p> <p>Inspect vertical arms, handrails and pivot pins for visible wear or damage</p> <p>Inspect upper/lower fold arms, saddle, saddle support and associated pivot pins, bushings, and bearings for visible wear or damage</p> <p>Inspect gas springs (cylinders - 4) for wear or damage, proper operation and positive securement</p>	<p>Resecure, replace or correct as needed</p> <p>Use Braun 32840-QT (Exxon® Unisolv HVI 26) hydraulic fluid (do not mix with Dextron III or other hydraulic fluids). Check fluid level with platform lowered fully and roll stop unfolded fully. Fill to within 1/2" of the bottom of the 1-1/2" fill tube (neck).</p> <p>Tighten, repair or replace if needed.</p> <p>Replace if needed.</p> <p>Tighten or replace if needed.</p> <p>Replace damaged parts and lubricate if needed</p> <p>Replace if needed.</p> <p>Tighten, replace or correct as needed</p>
<p>4500 Cycles</p>		
<div style="border: 1px solid black; padding: 2px; display: inline-block;">continued</div>		

Maintenance and Lubrication Schedule

<div style="border: 1px solid black; padding: 2px; width: fit-content; margin-bottom: 10px;">continued</div> <div style="text-align: center; font-weight: bold; font-size: 1.2em;">4500 Cycles</div>	<p>Inspect saddle bearing (1) and saddle bearing buttons (2)</p> <p>Inspect vertical arm plastic covers</p> <p>Inspect power cable</p> <p>Mounting</p> <p>Decals and Antiskid</p>	<p>Apply Door-Ease or replace if needed. See Lubrication Diagram.</p> <p>Resecure or replace if needed.</p> <p>Resecure, repair or replace if needed.</p> <p>Check to see that the lift is securely anchored to the vehicle and there are no loose bolts, broken welds, or stress fractures.</p> <p>Replace decals if worn, missing or illegible. Replace antiskid if worn or missing.</p>
<div style="font-weight: bold; font-size: 1.2em;">Consecutive 750 Cycle Intervals</div>	<p>Repeat all previously listed inspection, lubrication and maintenance procedures at 750 cycle intervals.</p>	

Lift Electrical Schematic

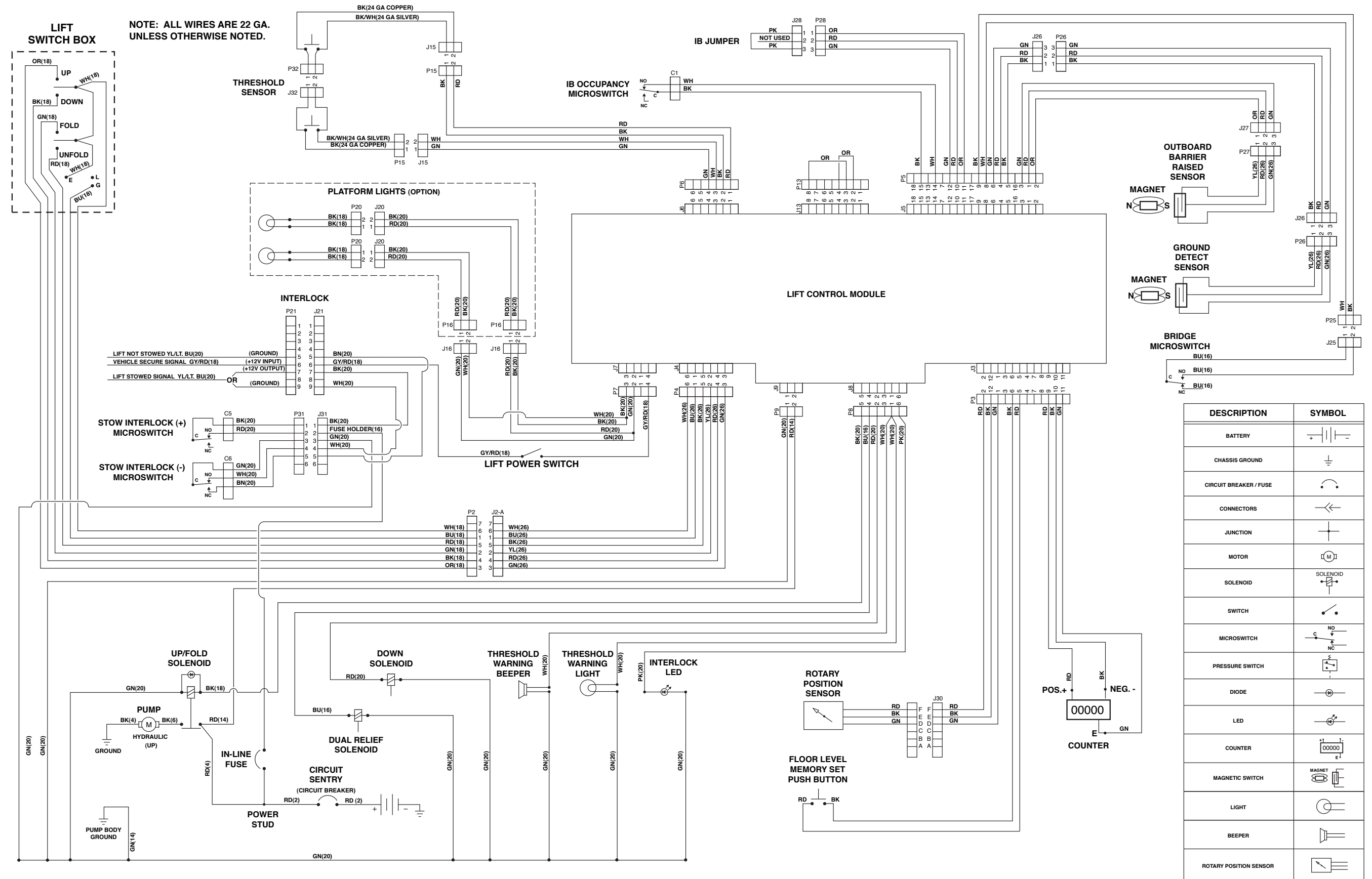

DESCRIPTION	SYMBOL
BATTERY	
CHASSIS GROUND	
CIRCUIT BREAKER / FUSE	
CONNECTORS	
JUNCTION	
MOTOR	
SOLENOID	
SWITCH	
MICROSWITCH	
PRESSURE SWITCH	
DIODE	
LED	
COUNTER	
MAGNETIC SWITCH	
LIGHT	
BEEPER	
ROTARY POSITION SENSOR	

Lift Wiring Diagram

Unfold for:
Lift Electrical
Schematic

Note: All wires 22 GA. unless otherwise noted.

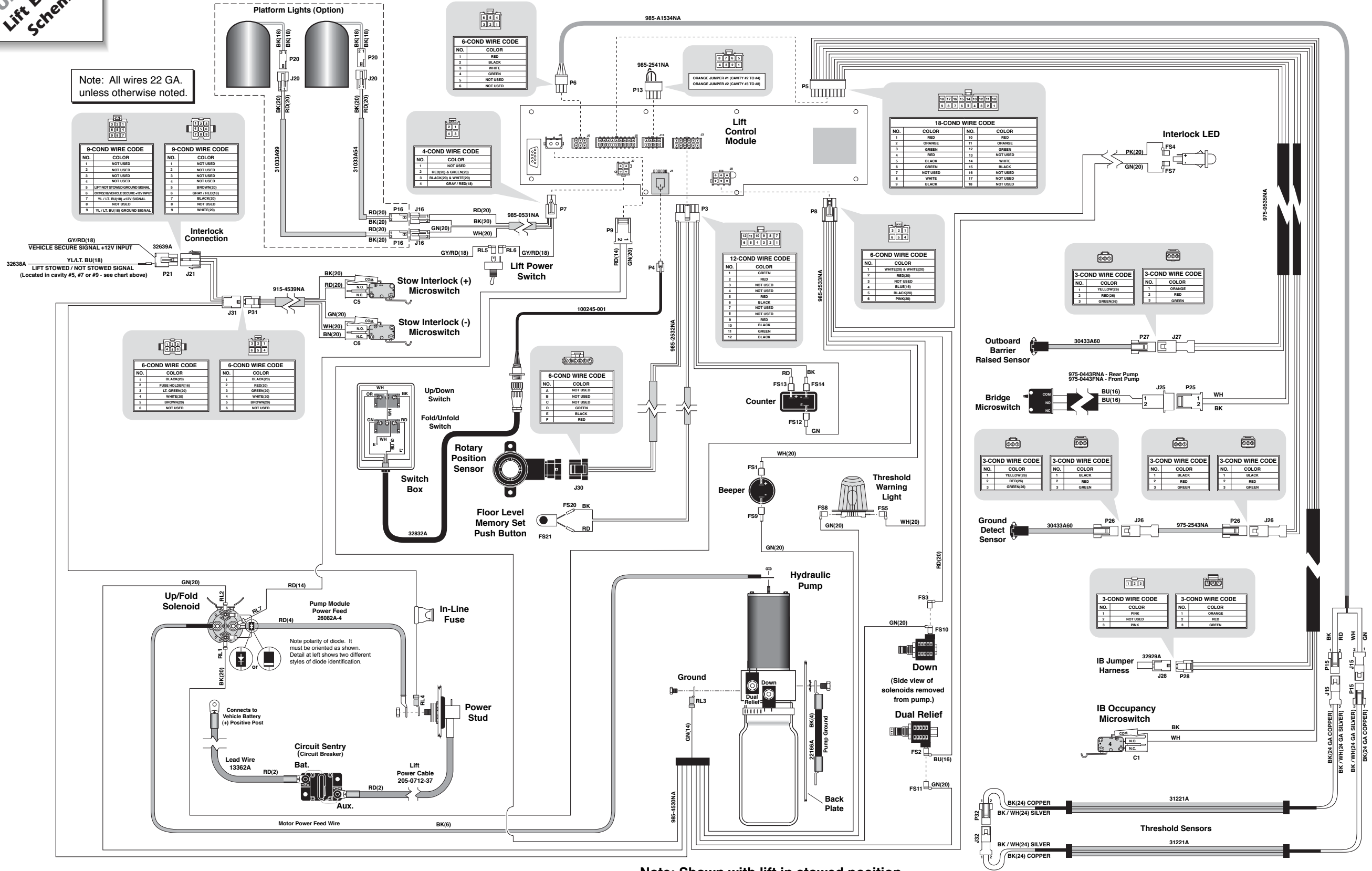

9-COND WIRE CODE

NO.	COLOR
1	NOT USED
2	NOT USED
3	NOT USED
4	NOT USED
5	LIFT NOT STOWED SIGNAL
6	DRIVEN VEHICLE SECURE +12V INPUT
7	YL / LT BU (18) +12V SIGNAL
8	NOT USED
9	YL / LT BU (18) GROUND SIGNAL

6-COND WIRE CODE

NO.	COLOR
1	BLACK(20)
2	FUSE HOLDER(18)
3	LT GREEN(20)
4	WHITE(20)
5	BROWN(20)
6	NOT USED

6-COND WIRE CODE

NO.	COLOR
1	RED
2	BLACK
3	WHITE
4	GREEN
5	NOT USED
6	NOT USED

4-COND WIRE CODE

NO.	COLOR
1	NOT USED
2	RED(20) & GREEN(20)
3	BLACK(20) & WHITE(20)
4	GRAY / RED(18)

12-COND WIRE CODE

NO.	COLOR
1	GREEN
2	RED
3	NOT USED
4	NOT USED
5	RED
6	BLACK
7	NOT USED
8	RED
9	BLACK
10	BLACK
11	GREEN
12	BLACK

18-COND WIRE CODE

NO.	COLOR	NO.	COLOR
1	RED	11	ORANGE
2	ORANGE	12	GREEN
3	GREEN	13	NOT USED
4	RED	14	WHITE
5	BLACK	15	BLACK
6	GREEN	16	NOT USED
7	NOT USED	17	NOT USED
8	WHITE	18	NOT USED
9	BLACK		

3-COND WIRE CODE

NO.	COLOR
1	YELLOW(20)
2	RED(20)
3	GREEN(20)

3-COND WIRE CODE

NO.	COLOR
1	ORANGE
2	RED
3	GREEN

3-COND WIRE CODE

NO.	COLOR
1	YELLOW(20)
2	RED(20)
3	GREEN(20)

3-COND WIRE CODE

NO.	COLOR
1	BLACK
2	RED
3	GREEN

3-COND WIRE CODE

NO.	COLOR
1	BLACK
2	RED
3	GREEN

3-COND WIRE CODE

NO.	COLOR
1	PINK
2	NOT USED
3	PINK

3-COND WIRE CODE

NO.	COLOR
1	ORANGE
2	RED
3	GREEN

Note: Shown with lift in stowed position.

Hydraulic Schematic

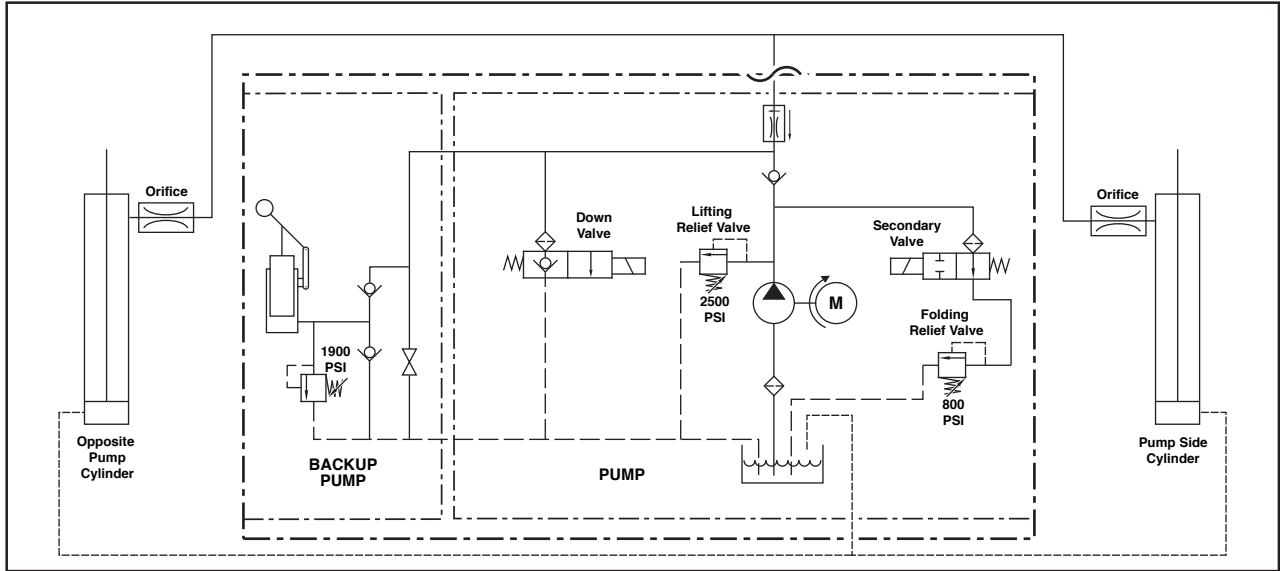

Description	Symbol	Description	Symbol
Fixed Displacement Pump		Hydraulic Port	
Pump Motor		2 Way 2 Position Solenoid Valve	
Backup Pump		Pressure Compensated Flow Control	
Single Acting Cylinder		Relief Valve	
Check Valve		Filter Screen	
Unfold Orifice		Vented Reservoir	
Manual Shutoff Valve			

Hydraulics Parts List

Item	Qty.	Description	Part #
1	1	Pump Assembly (M-268-0112) 120G / 12V / Dual Relief	30915-12V
2	1	Lead Wire Assembly, #6 Gauge	29049
3	1	Clamp, Hose (M258)	29663
4	1	Diode Assembly, Up Solenoid	73906A
5	1	Solenoid, 4-Post - Prestolite	28308
6	1	Motor, Pump - 12 Volt - Low RPM	29690
7	1	Valve Assembly, "Dual Relief" (complete)	31120K
8	1	Cartridge (only), "Dual Relief" Valve - (shown below)	31121
9	2	Coil (only) - (shown below)	31122
10	1	Valve Assembly, "Down" (complete)	31348K
11	1	Cartridge (only), "Down" Valve - (shown below)	26078
12	3	Screw, 1/4-20 x 2-1/4", Allen Head	26080
13	1	Hand Pump (Backup) with O-Rings (Item 14)	26074
14	4	O-Ring (only), Hand Pump Mounting	17351
15	1	Clamp, Reservoir - H-48 (M259)	17069
16	1	Reservoir, Hydraulic Fluid	30160
17	1	Cap, Reservoir Filler - Screw On	30167
18	1	Fitting, 90° - 1/8" NPT x 1/8" Barb - Plastic	87563
19	1	Connector, Plastic "Y", 1/8" O.D.	18877
20	1	Hose, Thermal Plastic - Black, 1/8" I.D.	23742R* (6")
21	1	Handle with Grip	17206A
22	1	Fitting, Male 7-16-20 SAE O-Ring to Male 7/16-20 JIC 37°	24504
23	1	Elbow, 7/16-20 JIC 37 Female Swivel (1) - 7/16-20 JIC 37° Male (2)	26579
24	1	Hose Assembly, 1/8" (Opposite-Pump-Side)	16004A-086
25	1	Hose Assembly, 1/8" (Pump-Side)	16004A-046
26	2	Elbow, 90°, 7/16-20 SAE O-Ring Male - 7/16-20 JIC 37° Male, Orifice	26667
27	2	Cylinder ✓	C1514.3-9408
28	2	Elbow, 90°, 1/4 NPT Male to 1/4" Barbed	15150
29	1	Hose, Thermal Plastic - Black, 1/8" I.D.	23742R* (68")
30	1	Hose, Thermal Plastic - Black, 1/8" I.D.	23742R* (30")

✓ **Seal Kits:** If repairing a cylinder, order Seal Kit #1500-0500P.

* Raw material items ordered and priced per inch (order specified length).

Hydraulic Fluid

When adding or changing hydraulic fluid, use Braun 32840-QT (Exxon® Univis HVI 26) hydraulic fluid (**do not mix** with Dextron III or other hydraulic fluids).

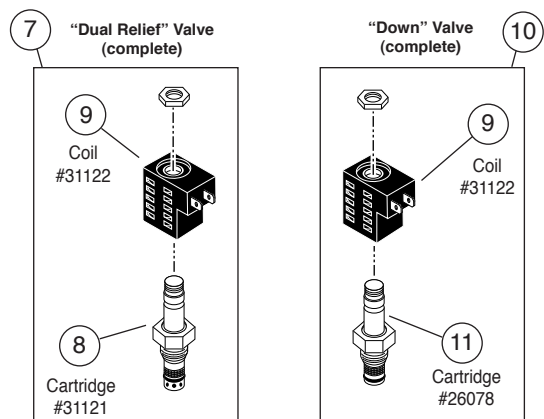

Hydraulics Diagram

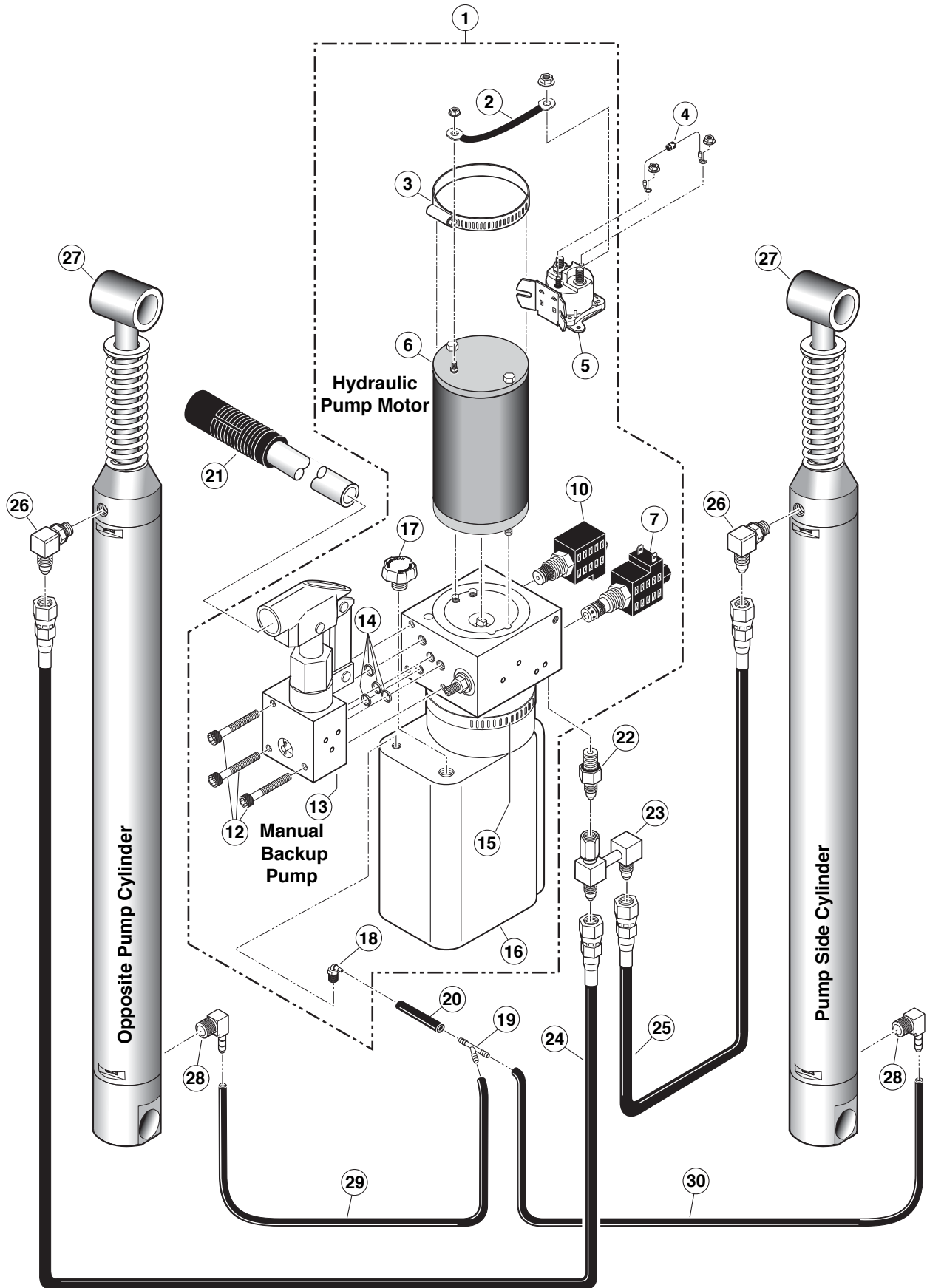

Pump Module Parts List

Part Numbers of Items Dedicated per Lift Model				
Item	Qty.	Description	NVL9171B	NVL9171B
	1	Pump Module (complete), 12 Volt, Rear	985-5516RNA	985-5516FNA
1	1	Plate, Backing / Mounting - Rear	985-2501RN	985-2501FN
2	1	Cover, Pump, 2-Piece - Back / Bottom (915-0513RNAPT or 915-0513FNAPT Includes Items 2 and 15 - 21)	915-0513RNPT	915-0513FNPT
3	1	Cover, Pump - 2-Piece - Top / Front (985-0519RNAPT or 985-0519FNAPT Includes Items 3 and 38 - 50)	915-0519RNPT	915-0519FNPT
Part Numbers of Items Identical on all Lift Models				
Item	Qty.	Description	Part No.	
4	1	Pump Assembly (M268-0112) 12V-120G - Dual Relief / ARS (Includes Items 5 & 6)	30915-12V	
5	1	Power Cable, Up Solenoid to Motor	29049	
6	1	Solenoid, Up - 4-Post - Prestolite	28308	
7	1	Clamp, Hose - Solenoid Mounting	29663	
8	1	Diode Assembly, Up Solenoid	73906A	
9	1	Fitting, Male 7/16-20 O-Ring to Male 7/16-20 JIC 37°	24504	
10	1	Elbow, Female Swivel 7/16-20 JIC 37° to (2) Male 7/16-20 JIC 37°	26579	
11	1	Control, Hand Pendant Assembly (See below for available options)		
11a	-	Control, Hand Pendant Assembly - Non-Shielded Cable - Straight ♦See note below	32832A	
11b	-	Control, Hand Pendant Assembly - Shielded Cable - Straight ♦See note below	32833A	
11c	-	Control, Hand Pendant Assembly - Shielded Cable - Coiled ♦See note below	32421A	
12	1	Control Board Assembly	100159-001	
13	8	Standoff, Snap-In	31011	
14	1	Switch, Push Button	31753	
15	1	Recepticle, Clip On	28803	
16	1	Lens, Threshold Warning - Red	30704	
17	1	Decal, Warning / Pressure Relief Valve (Not shown)	22249	
18	1	Spacer, Lens - NHTSA	31386	
19	1	Metal Ring Base - Lamp	30971	
20	1	Socket, Lamp	30703	
21	3	Screw, #8-32 x 1/2" Pan Head Phillips - Thread Cut	30974	
22	1	Bulb, Light	19841	
23	1	Diode, Green LED, Panel Mount	29545	
24	4	Rivet, Snap - .124" Hole x .197"/.236" Thick	29874	
25	2	Washer, 5/16" Flat	10063	
26	2	Bolt, 5/16-18 x 3/4", Nylock, Hex * See note below	29608	
27	2	Bolt, 5/16-18 x 1/2", Nylock, Hex * See note below	10012	
28	1	Cable, Ground	22166A	
29	1	Washer, 5/16" External Tooth	16368	
30	1	Beeper, Constant - High Output	33251	
31	1	Switch, Toggle	31787	
32	1	Decal, Lift Power - On/Off (Not shown)	21494	
33	1	Stud, Power Feed	26084	
34	1	Rubber Boot, Red ♦See note below	82046	
35	1	Harness, Lift Interlock Connection	32639A	
36	1	Wire Assembly, Lift Stowed Connection ♦See note below	32638A	
37	1	Pump Handle with Grip	17206A	
38	3	Rivet, Pop, SD43BS - 1/8" - .13"/.19"	12954	
39	1	Plug, Window - Clear	30443	
40	1	Stud, Wing Head - 1/4 Turn	28804	
41	1	Retainer, Push On	28805	
42	1	Washer, Nylon, 1/4" I.D. x 11/16" O.D. x .030"	12690	
43	1	Clip, Pump Handle - Top	915-5517	
44	1	Clip, Pump Handle - Bottom	915-5518	
45	1	Decal, Manual Instructions - Public (Not shown)	31412	
46	1	Decal, Removal / Installation - Pump Cover (Not shown)	29051	
47	1	Decal, Warning - Control Board Damage - ESD (Not shown)	30787	
48	1	Decal, Removal / Installation Pump Handle (Not shown)	29052	
49	1	Decal, Dual Relief Adjustment (Not shown)	32201	
50	1	Decal, LCD Lift Codes (Not shown)	32410	
51	1	Cable, Pump Module Power Hookup (Not shown)	26082A-4	
52	1	Harness, Power - Stow Interlock (Not shown - see Wiring Diagram)	985-4530NA	
53	1	Harness, Interlock / Lighting (Not shown - see Wiring Diagram)	985-0531NA	
54	1	Harness, Up / Down Solenoid (Not shown - see Wiring Diagram)	985-2533NA	
55	1	Harness, Threshold Switch Extension (Not shown - see Wiring Diagram)	985-A1534NA	
56	1	Harness, Stow Interlock (Not shown - see Wiring Diagram) ♦See note below	915-1538NA	
57	1	Harness, Hand Control - Pump Housing to Circuit Board (Not shown - see Wiring Diagram)	100245-001	
58	1	Harness, Jumper (Not Shown - see Wiring Diagram)	985-2541NA	

* Apply red #271 Thread Locker Loctite® to the four hex bolts (items 26 and 27) if a blue nylon patch is not present on the bolts when retrofitting an M268 pump assembly. Loctite® is available from The Braun Corporation under part number 11522-1.

♦ Indicates items available for replacement part purposes **only**. These items **are not** included with replacement pump modules.

Pump Module Diagram

Pump Mounting Bolts

Apply red #271 Thread Locker Loctite® to the three pump mounting bolts (items 26 and 27) if a blue nylon patch is not present on the bolts when retrofitting an M268 pump assembly. Loctite® is available from The Braun Corporation under part number 11522-1.

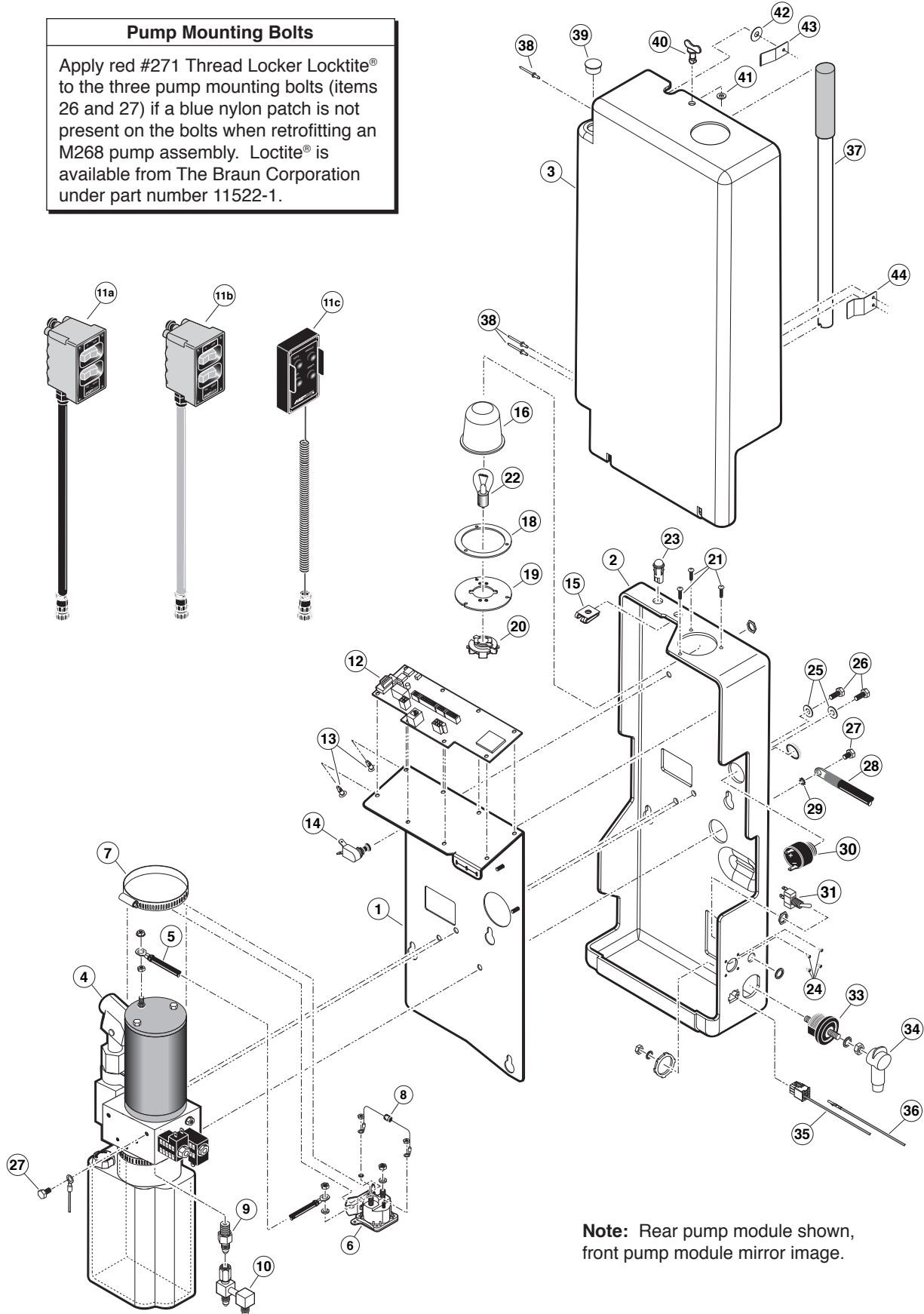

Note: Rear pump module shown, front pump module mirror image.

Repair Parts List

Part Numbers of Items Dedicated per Lift Model				
Item	Qty.	Description	NVL9171B	NVL9171B
1	1	Base Weldment	975F5148NW33	975F5148NW33
2	1	Cover, Pump, 2-Piece, Back-Bottom	915-0513RNPT	915-0513RNPT
3	1	Cover, Pump, 2-Piece, Top-Front	915-0519RNPT	915-0519RNPT
4	1	Assembly, Link, Outer Barrier, Rear	975-0219RNA	975-0220RNA
5	1	Assembly, Link, Outer Barrier, Front	975-0219FNA	975-0220FNA
6	1	Bridge Switch Assembly	975-0443RNA	975-0443FNA
7	1	Block, Platform Stop - Bridging - Rear	25778	900-0311
8	1	Block, Platform Stop - Bridging - Front	900-0311	25778
9	1	Plate, Backing/Mounting	985-2501RN	975-2437FA
10	1	Parallel Arm Assy., Top-Front w/Bearings	915-0437FA	985-5437FNA
11	1	Parallel Arm Assy., Top-Rear w/Bearings	985-5437RNA	975-2437FA
12	1	Parallel Arm Assy., Bottom Rear w/Bearings and Sensors	975-0458NA	917-0457NA
13	1	Parallel Arm Assy., Bottom Front w/Bearings	917-0457NA	975-0458NA

Part Numbers of Items Identical on All Lift Models							
Item	Qty.	Description	Part No.	Item	Qty.	Description	Part No.
14	14	Washer, 5/16" I.D. x 1" O.D. x .0269", Auto BK	15328	106	10	Screw, 5/16-18 x 3/4", SHFS	25527
15	4	Washer, Finger, Disc Spring	27276	107	2	Spacer, UHMW, Vertical Channel	995-0320
16	8	Snap-Ring 1/2"	13273	108	2	Washer, .376" I. D. x .563" O.D., .032" T-18-8 SS	31514
17	4	Snap-Ring 5/16"	24570	109	2	Bracket, Mounting, Quiet Ride	915-0392
18	4	O-Ring, 5/16" I.D. x 1/16" O.D.	26614	110	2	Gas Spring, 12.2" Extended/8.3" Compressed	30550A
19	2	Screw, Socket Head, 3/8-16 x 1/2" with 1/2" Shoulder	25929	111	2	Bolt, 5/16-18 x 3/4", Carriage, Black	15858BK
20	1	Gear Assembly, Front	975-2328FRABKN	112	5	Washer, 5/16", External Tooth	16368
21	1	Gear Assembly, Rear	975-2328RRABKN	113	4	Nut, 5/16-18 Hex	10058
22	4	Nut, 1/4-20 Hex Lock	10775	114	2	Bracket, Inner Side Panel Guide	915-0703
23	1	Stud, Wing Head	28804	115	3	Bearing, UHMW, Flat, Thin, Black	916-5406
24	1	Retainer, Push-On	28805	116	2	Pivot, Bridge Plate Lever, Upper, Inside	916-5433
25	1	Grommet, ID .312", FR .250", GD .813" T500"	27726	117	4	Bearing, Flange - 3/4" x 1/2"	24027
26	1	Pump Assembly, (M268 with Backup Pump)	30915-12V	118	1	Weldment, Latch Foot, Rear	975-0204RNV
27	10	Pin, Pivot, Parallel Arm	917-0403	119	1	Weldment, Latch Foot, Front	975-0204FNV
28	10	Screw Drive #8 x 3/16" Long Black	31086BK	120	2	Rod, 5/32" Torsion Spring Bar, Front	28132F
29	1	Receptacle, Clip-On	28903	121	2	Rod, 5/32" Torsion Spring Bar, Rear	28132R
30	2	Bumper, Stow, Millennium	26154	122	4	Screw, #4-40 x 3/16" THD FORM	31043
31	2	Bolt, 5/16-18 x 1/2", Button Head, Socket Cap	26281	123	1	Position Sensor Collet	31093
32	8	Rivet, Pop, SD4385 - 1/8" - 13/19	12954	124	1	Weldment, Tube-IB Fold Arm-Rear	975-0625RNV
33	4	Bolt, 5/16-18 x 1/2" Nylock, Hex	10012	125	2	Collar, Outer Barrier, Torsion Bar	975-2208
34	2	Washer, 5/16" Flat	10063	126	4	Nut, 3/8-16, Hex	10059BK
35	2	Bolt, 3/8-16 x 1/2" Nylock, Hex	29729	127	1	Weldment, Tube-IB Fold Arm-Front	975-0625FNV
36	2	Bolt, 5/16-18 x 3/4", Button Head, Soc Cap Hd	24440	128	8	Screw, 5/16-18 x 5/16", Set	11567
37	2	Bolt, 3/8-16 x 3/4" GR5-Hex, Auto, BK	12463	129	2	Bolt, 5/16-18 x 1 1/2" Hex Head, Cap	10014
38	2	Bolt, 5/16-18 x 3/4" Nylock, Hex	29608	130	2	Bolt, 7/16-20 x 1", SHCS, w/Nylock Patch	28474
39	2	Pin, Bearing, Platform Side	975-2360	131	4	Ring, 3/8" Retaining Snap	13889
40	2	Gear Rack, Platform Fold	975-2329BKN	132	6	Screw, #10-32 x 1/2, Flat Head-Hex w/Patch	17192P
41	10	Bearing, Flange, 1/2" x 1/4"	24442	133	8	Washer, Thrust, 1.125" O.D., .625" I.D., .0585" THK	29378
42	1	Weldment, Latch, Lift/Tite, Rear	29412RW	134	6	Rivet, Pop, 3/16"- .25"/.38", Black	14993
43	1	Weldment, Latch, Lift/Tite, Front	29412FW	135	4	Bearing, Flange, 10MM x 12MM, FMB1012DU	28128
44	2	Screw, #4-40 x 5/8", Round Head	14810	136	2	Nut, 1/4-20 x 3/16", Outer Barrier	975-0205N
45	2	Clip, Cable, 5/16", Plastic	26948	137	2	Washer, Nylon, .34" I.D. x .74" O.D. x .62" T	31439
46	1	Screw, #8-32 x 1", Mach. Truss Head	19912BK	138	2	Bolt, 1/4-20, Shoulder, Outer Barrier	995-0211
47	2	Nut, #4-40 w/Lockwasher	19537	139	2	Nut, 5/16-18, Top Lock, Black	28324BK
48	2	Nut, #8-32, Hex	10777	140	2	Bolt, 1/4-20 x 1/2", Button Head Socket	15733
49	1	Assembly, IB Occupied	31643A	141	2	Bolt, 3/8-16 x 2", Hex Head, Cap	10027
50	2	Cylinder, 14.625" x 1.146" Retracted	C1514-3-9408	142	2	Roller Assembly	1000-2395A
51	1	Inner Roll Stop	915-0147NWY	143	2	Roller Retainer	915-5353
52	16	Bearing, Flange, 3/4" x 3/8"	24011	144	2	Nut, 5/16-18 Hex, Lock	11387BK
53	8	Bushing, 3/4" I.D. x 1/2"	900-0456	145	2	Pivot, Bridge Plate Lever, Upper-Outer	916-5434
54	1	Vertical Channel Weldment, Front, 48"	975-0448FNV	146	1	Clamp, 1/4" I.D. - Nylon Loop	84396
55	1	Cover, Plastic, Parallel Arm, O/S Front-w/Tape	915-0704NA	147	2	Washer, 3/8" Flat, Black	10064
56	2	Tape, 1" Wide S-Face Foam, x 14" (1 Shown)	82015R014	148	6	Rivet, Snap, .201" x .256"/.295"	26362
57	6	Tape, 1" Wide S-Face Foam, x 10" (3 Shown)	82015R010	149	4	Bearing, Flange, 1" x 1/2-16FDU08	28031
58	1	Cycle Counter-LCD Without Reset	30547	150	1	Cover, Plastic, Parallel Arm, O/S Rear-w/Tape	915-0702NA
59	2	Handrail Weldment	985-4618NW	151	1	Weldment, Bridgeplate Bracket, Front	985-0431FNV
60	8	Rivet, Push In - 8MM	30063	152	4	Spacer, Handrail, .375" Thk. UHMW	995-0301
61	2	Bumper, Rubber, 31/32" O.D.	10950	153	2	Washer, 5/16" I.D. x .75" O.D. x .250", Black	25336
62	2	Screw, #8-18 x 1/2", Self-Tap, Phillips	13583	154	1	Cover, Plastic, Parallel Arm, I/S Rear-w/Tape	975-0703NA
63	2	Bulb, Light 20-W, Halogen Reflector	31060	155	1	Weldment, Bridgeplate Bracket, Rear	985-0431RNV
64	2	Washer, .328" I.D. x .75" O.D., .062" T-UHMW	31438	156	2	Spring, Torsion - .366 I.D. x .05"	30386
65	1	Base Cover Assembly - 33" (Traction Tape Not Shown)	975-5148CNA33Y	157	4	Spacer, IB Lock	30394
66	6	Washer, Thrust, .875" O.D., .50" I.D., .058" ST	29371	158	2	Weldment, IB Lock	985-0630NW
67	4	Nut, 3/8-16, Hex Lock	13617	159	4	Bearing, 3/8" I.D. x 1/2" Long	30405
68	2	Cotter Pin, 1/4" x 2", Black	15886BK	160	4	Roller, .65" O.D. x 1/2" Long	985-0631N
69	4	Washer, 1/4" Flat	10062	161	4	E-Clip, 3/8" Shaft	84383
70	1	Cover, Plastic, Parallel Arm, I/S Front-w/Tape	975-0701NA	162	2	Spacer, Handrail, .230" Thk. UHMW	911-5301
71	2	Threshold Strip Switch	31221A	163	4	Bearing, Flange, 3/8" I.D. x 1/4"	24028
72	4	Retainer, Push, 5/32" Threadless Shaft	31728	164	2	Screw, 1/4-20 x 3/4" BHSGS 18-8 SS	81068-000
73	2	Bolt, Shoulder, 5/16" x 5/8", 1/4-20 Thread	31816	165	1	Assembly, Rotary Position Sensor	31094A
74	10	Washer, 1/2" Flat Black Zinc	25346	166	2	Washer, .390" I.D. x .75" O.D., .21" T-UHMW	31440
75	4	Bolt, 3/8-16 x 1", Hex	10025	167	2	Light Assy, Vertical Channel	31062A
76	6	Washer, 3/8", Lock, Black	10069BK	168	2	Pad, Outer Barrier, Foot Stowed	975-2379
77	2	Lever, Inboard Outer Barrier	975-0404N	169	4	Plug, Interior, Plastic Push, Black	P50067-BK
78	4	Clamp, Insulate, 1 3/8" I.D.	29765	170	4	Spacer, UHMW-.75" O.D. x .39" I.D. x .25"	30227
79	4	Washer, 5/16" Lock, Black	10068	171	4	Bearing, Platform, Slide	975-2359
80	2	Gas Spring, Fold Arm	29186	172	2	Harness, Sensor, Magnetic w/Plug - 60"	30433A60
81	2	Ball Stud, Gas Spring, 13MM x 3/8-16 F. Thread	29185	173	2	Pin, Bearing, Gear Rack	975-2334
82	6	Washer, 3/8", Lock	10069	174	1	Platform Weldment Movable Outer	975-5336NV
83	2	Screw, 1/4-20 x 1/4", Set	11563	175	4	Screw, #10-32 x 1/2" Button Head, Socket, Cap	30375WP
84	2	Clip, Safety, 3/8-16 x 3/4", Flange	12608	176	2	Bearing, Platform, Slide	975-2358
85	6	Bolt, 3/8-16 X 3/4", Flange Button Head, Socket Cap	25171	177	1	Slide, UHMW, Platform Rotate	31677
86	2	Bolt, 5/16-18 x 2", Flange, Hex	25130	178	5	Rivet, Pop, 3/16" - .13/.25" - SD64BS	11513
87	2	Nut, 5/16-18, Serrated Flange	25131	179	2	Spacer, 5/8" I.D., 7/8" O.D. x 3/16" L-UHMW	31678
88	2	Arm, Slide Support (Replace In Pairs)	985-6612N	180	1	Position Sensor Spacer	31092
89	2	Slide, Platform, Rotate	985-0606N	181	2	Link, Weldment, Platform, Vertical Channel	975-2333W
90	2	Spacer, 5" O.D. x .334" I.D. x 1.515" LG	25132	182	2	Pin, Bearing, Gear Rack	975-2202
91	10	Bearing, Flange, 3/4" x 1/4"	24012	183	1	Outer Barrier Pivot Arm Front	975-0216RNWY
92	2	Weldment, Platform Pivot Arm - 48"	985-0640NW-BKN	184	1	Outer Barrier Pivot Arm Rear	975-0216FNWY
93	2	Pin, Pivot, Lower Arm	900-0413N	185	2	Pin, Outer Barrier, Vista	975-0217N
94	6	Ring, Snap, 3/4", External	18657	186	2	Screw, 1/4-20 x 3/4", Flat Head, Socket, Countersink	28986
95	2	Bearing, UHMW, Flat, 1.226"	205-1760	187	2	Pin, Bearing, Platform Slide	975-2360
96	2	Ball Stud, 10MM	21301	188	2	Nut, #10-32 w/Lockwasher	18349
97	1	Vertical Channel Weldment, Rear	975-0448RNV	189	1	Bag, Vinyl - 7" x 10"	31174
98	6	Plastic End Cap, 1" I.D. x 1 1/4" O.D.	20474	190	3	Washer, #10, Flat, Auto BK	11541
99	2	Grip, Handle, Yellow	19074	191	1	Outer Barrier, 33"	975-0312NY
100	2	Spring, Dampener, Retract	26963	192	1	Platform Weldment Fixed Inner	975-03351NW
101	2	Bolt, 5/16-18 x 1 1/4" Low Socket Hd., Cap, Bk.	26327	193	1	Shim, Bracket, Hanger, Hand Pendant	33216
102	2	Bumper, .75" x .625" Long	915-0391	194	1	Bracket, Hanger, Hand Pendant	33215
103	2	Screw, 1/2-20 x 1 1/2" Set Lock, Black	18663	195	2	Bolt, Carriage, 1/2-20 x 1/2"	12777
104	2	Block, Guide-Platform Stow	28593	196	2	Clamp, Cable, 1/2", Plastic	10092
105	2	Pin, Platform	975-2325				

Exploded View

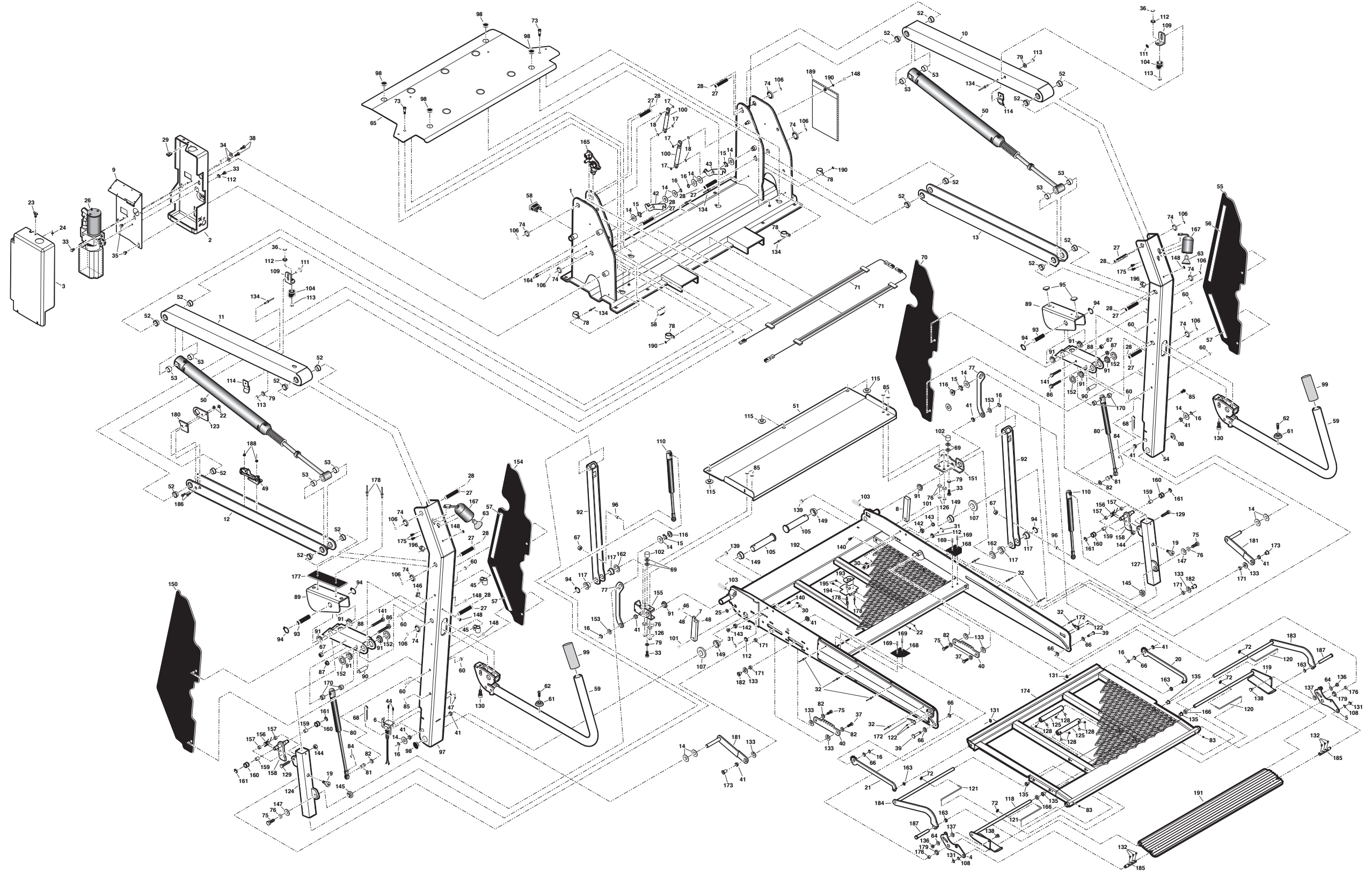

Unfold for:
Series A5 NVL9171B
Lift Exploded View

NOTES

This page intentionally left blank.

"Providing Access to the World"®



**Over 300 Braun
Dealers Worldwide**

 **THE BRAUN
CORPORATION**
"Providing Access to the World"®



International Corporate Hdqrs: P.O. Box 310 Winamac, IN 46996 USA
1-800-THE LIFT® (574) 946-6153 FAX: (574) 946-4670

**Braun™ Five-Year
Limited Warranty**

The Braun Corporation of Winamac, Indiana, warrants that it will repair (or replace at Braun's sole option) any defect in material or workmanship in its wheelchair lift for five years*, providing the lift is installed, operated and maintained properly. This warranty is limited to the original purchaser and does not cover defects in the motor vehicle on which it is installed, or defects in the lift caused by a defect in any part of the motor vehicle.

This warranty commences on the date the lift is put in service, providing the warranty registration card is completed and received by The Braun Corporation within 20 days of purchase. If no warranty card is received, the warranty will expire three years from the date of manufacture as identified on the lift serial number tag.

This warranty also covers the cost of labor for the repair (or replacement at Braun's sole option) of parts for three years when performed by an authorized Braun representative. (A labor schedule determines cost allowance for repairs and is available upon request).

This warranty does not cover normal maintenance, service, or periodic adjustments necessitated by use or wear. The Braun Corporation will not, under any circumstances, pay for loss of use, incidental, or consequential damages related to the lift or vehicle in which it is installed.

This warranty will become null and void if the lift has been damaged through accident, misuse, or neglect, or if the lift has been altered in any respect.

* The five-year portion of this warranty covers the following lift's power train parts:

- Cable ▪ Cylinder ▪ Flow Control ▪ Gear Box ▪ Motor ▪ Pump ▪ Hydraulic Hose & Fittings
- Solid State Controller

All remaining lift components are covered by a three-year warranty.

Return Authorization Procedure

When processing any warranty claims (parts, repairs, etc.), all requests must be processed through The Braun Corporation Product Support Department. Call 1-800-THE LIFT® during normal working hours. Product Support will issue a Return Material Authorization (RMA) number and detail the procedures required for processing returns and/or authorizing credit.

The lift identification information is provided on the Braun Serial No./Series No. identification tag and the two warranty cards (shown on inside front cover). The lift identification information must be provided when filing a warranty claim or ordering parts.



"Providing Access to the World"®

International Corporate Hdqrs: P.O. Box 310 Winamac, IN 46996 USA
1-800-THE LIFT® (574) 946-6153 FAX: (574) 946-4670

